



INSTALLATION AND MAINTENANCE MANUAL

Akvasmart Cameras and Winches

Basic HR Camera, Super HR Camera, SmartEye 360 Twin Camera

SmartWinch, Winch HT, Winch V5

D	16.11.16	Re-Approved (ECO-0000971)	EBL	BP
C	13.10.15	Re-Approved (ECO-0000809)	EBL	IL / PÅN
B	08.01.15	Re-Approved (ECO-0000614)	EBL	IL / PÅN
Rev	Date	Issued	Issued by	Approved by

Document no.:	DC10000920	Document part no.:	10001026	Project no.:	88073-01
----------------------	------------	---------------------------	----------	---------------------	----------



For a thorough introduction of Your AKVA product, we ask that all users read this entire manual. If questions occur, contact us!

The information in this document is subject to change without notice and should not be construed as a commitment by AKVA group ASA.

AKVA group ASA assumes no responsibility for any errors that may appear in this document.

In no event shall AKVA group ASA be liable for incidental or consequential damages arising from use of this document or of the software and hardware described in this document.

We reserve all rights in this document and in the information contained therein. Reproduction, use or disclosure to third parties without express authority is strictly forbidden.

This document can also be read and downloaded from our web site, see www.akvagroup.com/products/user-manuals

© 2016 AKVA group ASA (NO)

Table of contents

1	Safety	5
1.1	Safety symbols	5
1.1.1	Other symbols used in this manual	5
1.2	Personnel	6
1.2.1	Working inside the cage	6
1.2.2	Remote controlled winch	6
1.3	Receiving new equipment	7
1.4	Bad weather	7
1.5	Disinfecting equipment.....	7
1.6	Knots	8
1.6.1	Fastening ropes to the cage edge and to cables	8
1.6.2	Fastening ropes to bracket and nylon ring.....	8
1.6.3	Temporary fastenings for rope around cage edge.....	8
1.7	Product and parts	9
1.7.1	Blind plugs	9
1.7.2	Connections and cables	9
1.7.3	Pulleys.....	10
1.7.4	Suspensions	10
2	Introduction	11
2.1	How to use this manual.....	12
2.2	About AKVA group	13
2.3	About Akvasmart Cameras	14
2.3.1	HR Feeding Cameras	15
2.3.2	SmartEye Cameras	16
2.4	About Akvasmart Winches	17
2.5	About AKVAconnect	18
3	Camera cable	19
4	Suspending camera without winch	20
4.1	Installation procedure	21
4.1.1	Adjust camera position	22
4.2	Bringing the camera in for maintenance	23

5	Camera suspension with winch: Installing winch.....	26
5.1	Winch V5 installation	27
5.1.1	Preparing CAP connection box	28
5.1.2	Attaching CAP connection box to Polarcirkel and single steel poles.....	29
5.1.3	Attaching CAP connection box to double steel poles.....	30
5.1.4	Attaching Winch V5 to CAP connection box.....	31
5.2	Installing Smartwinch and Winch HT in steel cages	32
5.3	Installing Smartwinch and Winch HT in plastic cages	32
6	Camera suspension with winch	33
6.1	Suspensions for Winch V5.....	34
6.2	Suspensions for Winch HT	37
6.3	Suspensions for Smartwinch	41
7	Using Winxch V5	45
7.1	Manual control	45
7.2	Software control.....	45
8	Camera power supply and signal transmission	46
8.1	Wireless transmission, signals to and from winch and camera	46
8.2	Hardwired transmission, signals from cameras	46
9	Maintenance	47
9.1	Winch	47
9.2	Ropes and elastic bands	47
9.3	Pulleys	47
9.4	Camera	48
9.5	Maintenance plans	49
9.6	Weekly maintenance	50
9.7	Monthly maintenance	51
9.8	Registration of maintenance.....	52
	Appendix A - Index	53
	Appendix B - Deviation form	54
	Appendix C - Notes	55
	Appendix D - Contact information.....	57

1 Safety

Safety for the users of our equipment is top focus when AKVA group ASA develop new products and product manuals.

We therefore strongly recommend that everyone who uses the equipment, all who perform any type of repairs, service or other maintenance to the product, and all who work in areas where the product is installed, read this entire manual and at least this safety chapter.

This recommendation is based on both personnel safety as well as a desire to keep the products in order and avoid the risk of damages as a result of the safety instructions not being followed.

1.1 Safety symbols used in the manual

These safety symbols are used in this manual:



Information



Show caution, danger of damaging equipment and mild injuries to personnel



Danger! Will cause dangerous situations and danger for personnel



Warning - may cause personnel injuries

1.1.1 Other symbols used in this manual



Go to or see page or chapter for further instructions or more information

1.2 Personnel

The information in this chapter about safety and the remainder of this manual is not intended as a guaranty from AVKA group ASA. Personnel may be injured even though all safety procedures are followed as instructed.

The site owner is responsible for ordering that all site personnel aquire all information regarding safety and potential risks during work with, on or by cages, including this maintenance manual. All personnel must understand all such dangers before anyone staying on a cage edge.

Knowing how the cameras and winches are installed, used and maintained is a requirement before operating and working with, on or by the products. Site owner is responsible that all provided instructions are followed. This is not AKVA group ASA's responsibility.

1.2.1 Working inside the cage

Before divers go in to the cage, and when people in general are moving around inside the cage in boats or similar, all under water cameras must be removed from the cage.

1.2.2 Remote controlled winch

Site manager is responsible for informing all personnel that the Winch V5 is remote controlled, and that it may start moving when people are staying on or around the cage.

1.3 Receiving new equipment

Make sure that all parts are delivered according to the service note. If the order is not complete, or if any defects are discovered, contact AKVA immediately, contact information is found in the back of this manual. AKVA group ASA provides a 1 year warranty covering manufacturer's defects. The warranty is effective upon date of shipment to original recipient.

The following are reasons for a void of warranty:

- poor treatment of the system due to negligence of preventive recommendations
- improper use of power sources
- if the camera units is opened without express written consent from an AKVA group employee.

1.4 Bad weather

Make sure that all suspensions and equipment are ok after bad weather. Twirls between ropes and cables can cause the equipment to loosen and become damaged or cause damage to other equipment. Therefore, it is important to check that everything is in order after stormy weather. Tighten all fastening bolts as often as possible, and more often after stormy weather and extra motions in the cage. If anything is out of order or damaged or if assistance is needed, contact AKVA immediately.

1.5 Disinfecting equipment

If any of the equipment, ropes or other belonging parts are being moved to a new location, it is decreed by law to disinfect everything to prevent contamination. We recommend rinsing with fresh water after disinfection, because the disinfectants are strong chemicals that may damage the surface materials.

1.6 Knots

Always use correct and well tied knots when fastening cameras to cages. If the knots are not properly executed they may loosen, causing the camera to fall into the cage net which in worst case can cause fish escape. Remember that the knots have to be easy to untie after staying in the salt water over time. Salt water environments cause significant strain to ropes and especially to knots. When the camera are taken out of the water for maintenance and control after bad weather, easy knot untying is required.

1.6.1 Fastening ropes to the cage edge and to cables

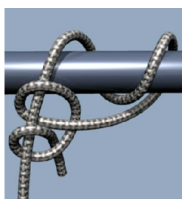

We recommend rolling hitch

1.6.2 Fastening rope to brackets and nylon ring

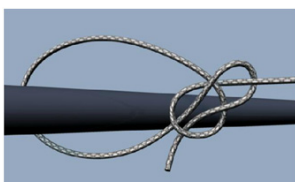

We recommend bowline knot

1.6.3 Temporary fastenings for rope around cage edge

(for instance during camera maintenance)

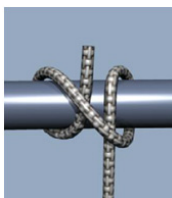

We recommend half hitch.

1.7 Product and parts

All equipment must be treated as described in this manual. The parts mentioned in this chapter are critical components, and poor treatment of these safety instructions may cause damages to the entire product.

1.7.1 Blind plugs

When receiving new cameras, check that the blind plugs are properly attached to the parts. Make sure that all plugs and their attachments are in order, in place and intact to avoid any damages. If blind plugs are damaged or are not being used as described in this manual, the warranty may be invalidated or reduced.

Blind plugs must be easy to locate when taking the equipment out of use for maintenance, service and repairs, and must be attached to both camera cable as well as EAP/CSU when these are not connected. If a blind plug is damaged or disappears, it has to be replaced immediately. Contact AKVA for ordering new plugs when needed. Contact information is found in the back of this manual.



1.7.2 Connections and cables

Treat all connections with great caution. These must always be covered when they are not being used.

Avoid twisting the sensor cable. Coil it only according to the instructions in chapter 3. Make sure that there is no tension to the cable, and make sure that the cable is in order, without any tears or damages, when it is connected to the power source. The cable must not be installed if it has any bends, tears or breaks.



1.7.3 Pulleys

Pulleys need regular cleaning to prevent them from sticking. Rinse off salt water residues with fresh water and brush away filth with a soft brush. Test the pulleys by removing ropes and spin the wheel. Replace the pulley if it is stuck.

1.7.4 Suspensions

Rope- and elastic band crossings are difficult to detect from the barge, therefore we recommend that they are checked for crossings and twirls from the cage end at least once a week. If the winches are controlled from the barge, crossing ropes may cause damages to the winch engine.

The following must be considered when installing camera suspensions in the cages:

- the circular plastic cages are in constant movement
- the white flag-line rope may stretch without going back
- tighten the ropes so that they do not spin on the winch, but not too tight, risking the ropes losing their elasticity
- elastic bands must not be tightened too hard, their elasticity will die after a while, test them regularly.

Ropes and elastic bands must be cleaned for salt water and sprout, then rinsed with fresh water regularly. We recommend doing this as often as maintaining the winch.

Make sure that the ropes are not touch other equipment installed inside the cage, for instant the rotor spreader. This avoids interfering damages during storms and bad weather.

2 Introduction

Thank you for choosing AKVA group ASA as supplier for your camera system. Do not hesitate to contact us for more information regarding maintenance for Akvasmart Cameras and Winches or any other AKVA products.

This user manual is part of the equipment delivered with Akvasmart Cameras and Winches. Keep the manual for as long as the products are being used, and make sure that all changes to the equipment are noted in the back of this manual.

The purpose of this manual is to enable the user to install, use and maintain the Akvasmart Cameras and Winches in a safe and economical way. This manual will hopefully answer any day-to-day-questions regarding the camera system.

If any necessary information is missing from this manual, please contact AKVA group for assistance and help to find a solution to any problems. Contact the AKVA service department, Your subcontractor, Your local AKVA office or our main office in Norway for assistance and help.

2.1 How to use this manual

This manual describes how to safely install and maintain the Akvasmart Cameras and Winches. This entire manual must be read and understood by ALL participants in the installation process prior to the installation.

The table of contents is listed in the start of the manual.

Chapter 1 is the most important chapter of the manual, listing all safety precautions, warnings and other safety information that ensures safe maintenance. Chapter 2 provides general information on AKVA group, information about the products included in this manual, and this usermanual-instructions.

Chapter 3 describes how to handle the camera cable. Chapter 4 describes suspensions for cameras without winch. Winch installation is described in chapter 5, and suspensions for cameras with winch are instructed in chapter 6. Chapter 7 shows how to use the Winch V5 with and without AKVAconnect. Chapter 8 illustrates power to and signal transmissions from cameras, and chapter 9 contains maintenance instructions, as well as maintenance frequency overview and maintenance registration forms.

Four appendixes are found in the back of the manual: Index, with links to the rest of the manual in the .pdf-manual, a deviation form for all deviations with the system, note pages for new and extra information are also in the back of the manual, and contact information is found in the back of the manual.



This entire manual must be read, understood, and used as aid during installation, use and maintenance work

2.2 About AKVA group

With four main brands, AKVA group ASA is a world leading supplier of technical aquaculture equipment. Since 1980 we have developed and produced fish farming equipment, both for cages at sea and for land based hatcheries. AKVA represents an industrial standard, which is assumed to be the key to the future. Research, project management, fast deliveries and customer follow-up have been our focus to ensure that we contribute to a positive development within the aquaculture industry. Our goal is to deliver the best possible and most cost efficient equipment in order to keep preserving sustainable fish farming.

We have a wide variety of products, for example: plastic and steel cages, high pressure washers, net washers, boats, feed barges, feeding systems, cameras, sensor systems, under water lighting, software for fish farming and recycling systems.

AKVA has a continuous development of products, and we continue to improve product safety, functions, range of use and reliability. All of our equipment is pre-installed, tested and delivered from our own production department. This means that our customers have total control over which components to choose from, grouping collocation, testing and deliveries. Our production staff consists of people with great expertise and engagement for producing the best possible products for you. Having our own production site gives you excellent service in case something should go wrong, or if you are in need of any assistance. Our service staff is available on the telephone or on location in order to assist you if necessary.

Safety, both for users and equipment is our main focus when developing products and product manuals.

2.3 About Akvsmart Cameras

More than 20 years of experience makes AKVA group ASA a competent and complete aquaculture camera supplier. We deliver everything from simple black and white cameras to advanced movable pan and tilt color cameras. In cage breeding, Akvsmart Cameras can be used to observe:

- under water feeding activity
- surface feeding activity
- fish behavior
- fish maturation
- parasites (sea lice)
- morts at the cage bottom

Advanced video-camera systems monitor the entire farm as well as the feeding process. This ensures safe and economical operations and better location environment.

These cameras are included in this manual:

Basic HR: 01001116, 0101619, 0104182, 0104183

Super HR: 0101123, 0101865, 0102483, 0102240

SmartEye ULL: 10002290

SmartEye MKII: 10000792, 10000851, 10000826, 10000829

2.3.1 HR Feeding Cameras

Akvasmart HR (High Resolution) Feeding Cameras are video cameras developed for visual control of the feeding process, and are the world's most sold feeding cameras. These cameras are stationary cameras hanging underneath the fish's eating area (typically at 5-8m) and look straight up to easily detect uneaten pellets passing the camera.

HR Feeding Cameras are dependable cameras, and can be wired to several hardwired or wireless camera networks. They may be operated from the cage, work-boats, feeding control rooms and via the Internet. These cameras give sharp and clear video images. One camera will usually be permanently installed in each cage.



Basic HR Camera

A simple, affordable and reliable camera. A reasonable choice, secures effective feeding control inside the cage.



Super HR Camera

Simple and robust design, this camera is the world's most used feeding camera. It is a reliable high resolution camera developed for use in any conditions. This model is available both as monochrome as well as color camera.

2.3.2 SmartEye Camera

Akvasmart SmartEye Cameras has main and bottom camera, both of these record sharp and crystal clear video images in color or black and white. The SmartEye Cameras have no movable parts, and this prohibits water penetration as well as increasing the operation safety. Combined with a SmartWinch or SmartWinch HT, this system gives total overview over what is happening in and around the cages, surveying the feeding process, the fish's condition and mortality. Extra equipment includes built-in depth- and temperature sensors. This camera system is connected to the base station via the wireless Akvasmart CAP-transmitter or the Akvasmart Digital CAP.



SmartEye 360 Twin Camera

A top class camera system, the markets most advanced fish farming camera. New SmartEye 360 Twin has two built-in cameras and has 360° horizontal AND vertical overview.



SmartEye 360 Twin Camera ULL

The ultra low light (ULL) term is used for cameras that are designed for use in areas with poor light conditions. Akvasmart SmartEye 360 Twin ULL cameras provide clear black and white video images from depths down to 246 feet (75 meters)

2.4 About Akvsmart Winches

Winches are installed on the cage edge, and camera suspensions are attached to the winch. Using winch enables moving under water cameras both vertically and horizontally inside the cage.

AKVA group has, over the last years developed three different winches, the last one, Winch V5, is stronger than all the previous variants.

Installation procedures varies for the various winches, and for different cage types, so make sure to use correct procedure for the specific winch and cage!

Our three types of Akvsmart Winches are:

Winch V5:

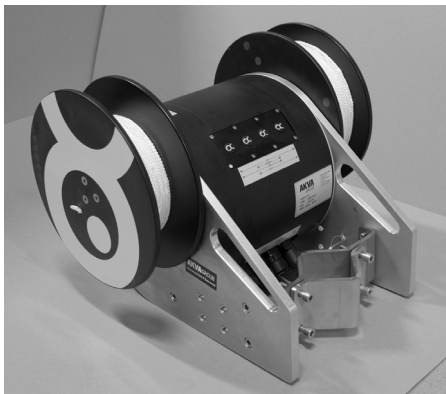

Winch HT Dual:



SmartWinch:



These winches are included in this manual:

Winch V5: 10001403

Winch HT Dual: 10000410, 10000372

SmartWinch: 0103392, 0103383

Akvsmart winches are compatible with all Akvsmart underwater cameras.

2.5 About AKVAconnect

AKVAconnect is a new process control platform software that is used to connect and control both small local sites, as well as large multi national aquaculture companies. It can be used for controlling both feeding, sensors and surveillance. AKVAconnect is a modular system, compatible with all types of equipment, sensors and technical installations. Smart 3D design with interactive control functions, makes AKVAconnect a simple and user friendly control software.

Used with Akvasmart Camera and Winch System, AKVAconnect is the most adaptable and user friendly system on the market. AKVAconnect is developed over the last 30 years in close cooperation with fish farmers all over the world. This has resulted in full integration with camera systems and environmental sensors.

AKAVconnect is used for camera surveillance, at the same time as data and other information is gathered from all components in all operating levels from one or several aquaculture sites. The program also shows all current values measured with available equipment installed and connected in the site(s). This improves control and surveillance of technical processes, providing improved company cost control.



Winch V5 may be used with AKVAconnect version 2.11 or newer.

3 Camera cable



Safety garments and antiskid foot wear is mandatory when working on or by the cage edge



Attach a lifting rope to the cable as close to the camera as possible, using rolling hitch knot. The rope must be longer than the cable to prevent stretching the sensitive cable



If the camera cable is too long, the redundant cable must be coiled up according to the instructions above to keep it away from the walking area

When taking the camera out of the cage, for maintenance, service or for any other reason, the camera cable must be coiled, as described below. It is important not to twist or bend the cable.

Procedure:

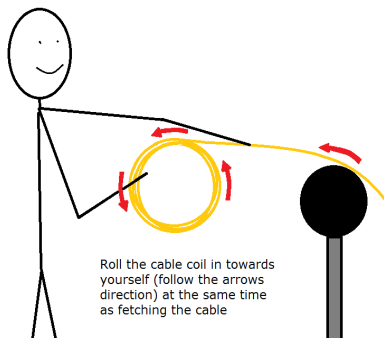

- 1 Read through this entire procedure before commencing the process
- 2 Make a loop and fasten the loop with plastic strips or a similar fastening device
- 3 Coil the cable around this loop
- 4 If the cable is being twisted, rotate the entire coil. This way twisting in the cable is avoided, and cable operating time will be prolonged
- 5 If excessive cable after placing the camera in the water, fasten the excessive coil with tape or plastic strips and fasten it to the cage edge out of the walking area around the cage.



4 Camera suspension without winch



Safety garments and antiskid foot wear is mandatory when working on or by the cage edge



Make sure to have enough rope to pull the camera between the cage sides and to tie them to the cage handrail

Cameras can also be attached in the cages without winch. In this case, the double pulley is replaced by a nylon ring. Use two horizontal ropes, one attached to the handrail on each side of the cage. These ropes are connected through a nylon ring positioning the camera inside the cage. The ropes have to be long enough to reach over the cage diameter, so that the camera can be pulled out of the water from both sides, plus enough rope to attach the rope to the handrail.

Use two ropes for horizontal camera positioning and one rope for vertical positioning.



Make sure that the knots are properly executed, use the recommended knots from chapter 1.4 or equivalent knots. If a knot were to loosen, the camera might fall into the net, and this can cause damages both to the camera and the net.

We recommend that this installation process is performed by two people, one on each side of the cage.



The illustration in the next page shows three separate ropes:

- Two ropes to adjust the camera's horizontal position
 - Both ropes has to be long enough to reach over the cage's diameter + attachment to the cage edge
- One rope to adjust the camera's vertical position
 - This rope has to be long enough to go to the camera's horizontal position + the camera depth + attachment to the cage edge

4.1 Installation procedure

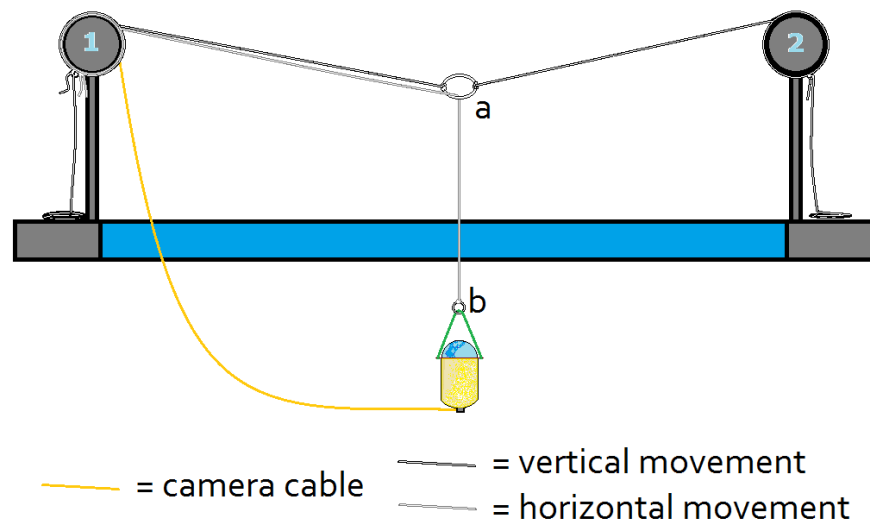

- 1 Read through this entire procedure before commencing the installation process
- 2 Tie both of the horizontal ropes to the nylon ring (pt. a) using bowline knots
- 3 Let person I stand at pt. 1 with one rope and the nylon ring
- 4 Person II brings the second rope to pt 2. Fasten both ropes to the cage edge or let the persons hold them
- 5 Person I threads the vertical rope through the nylon ring (pt. a) and fastens it to the camera's nylon fastening ring (pt. b) using a bowline knot



Make sure to secure the other end of the vertical rope to the cage edge to prevent it from sinking into the cage with the camera during the installation process

- 6 Person II pulls the horizontal rope in pt. 2 and person I loosens both the horizontal and the vertical rope in pt. 1, until desired horizontal position is reached

7 Fasten the horizontal ropes in points 1 and 2

8 Loosen the vertical rope until the camera is in the desired depth. Fasten the rope to the cage edge.



In order to maintain manual control with camera depth, the rope may be marked with knots, tape or other water proof markers for every or every other meter of rope. This may be useful for both cameras installed with and without winch.

4.1.1 Adjust camera position

Adjust the camera's horizontal position by loosening and pulling the horizontal ropes. Two people make horizontal positioning easier.

The camera's vertical position can be adjusted by loosening the knot on the vertical rope and:

- Pulling the rope – raising the camera
- Releasing the rope – lowering the camera

4.2 Bringing the camera in for maintenance



Safety garments and antiskid foot wear is mandatory when working on or by the cage edge



Fasten all of the ropes properly to the cage edge during the camera positioning process and also after all work and service tasks are performed

If the camera has to be taken out of the water for maintenance, repair or cleaning, loosen the horizontal ropes (make sure not to drop them!) from both sides of the cage edge before moving.

Procedure:

- 1 Read through this entire procedure before commencing the installation process
- 2 Release the rope in pt. 2 while pulling the rope in pt. 1 to bring the nylon ring (a) to pt. 1
- 2 Secure both of the ropes by tying them to the cage edges using half hitches so that they are easy to loosen when the camera is going back into the cage

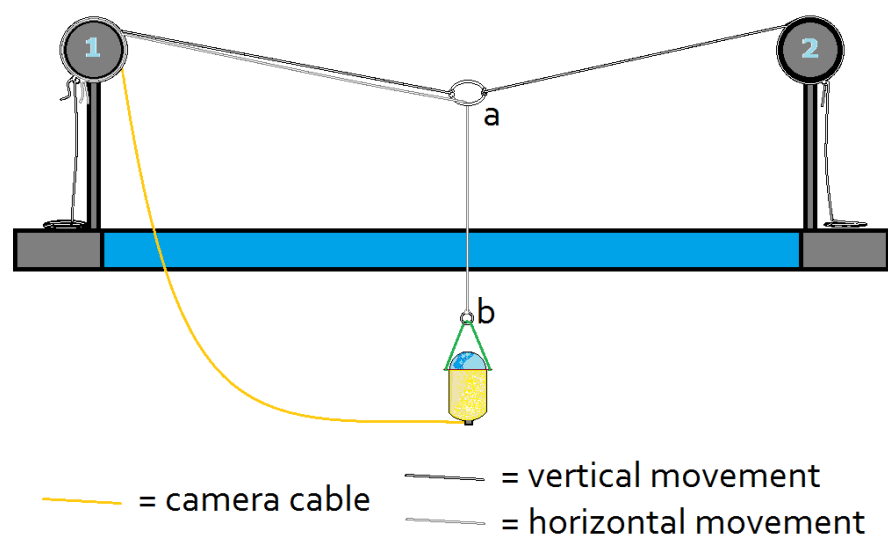

- 3 Pull the horizontal rope until the nylon ring reaches the hand rail. Reattach the rope

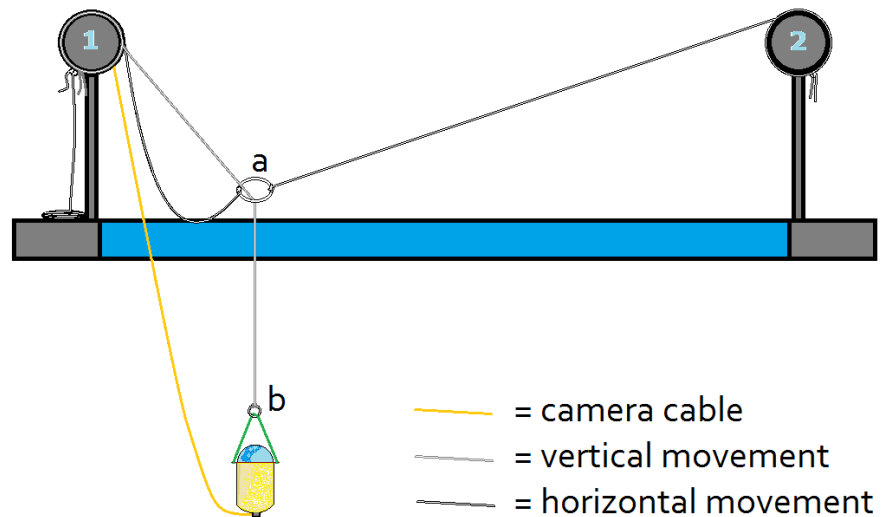

- 4 Pull the vertical rope and take the camera out of the water. Loosen the camera from the rope, disconnect the cable from the camera and attach a blind plug in both camera and cable connections. Also, see chapter 4 for instructions on handling the cable

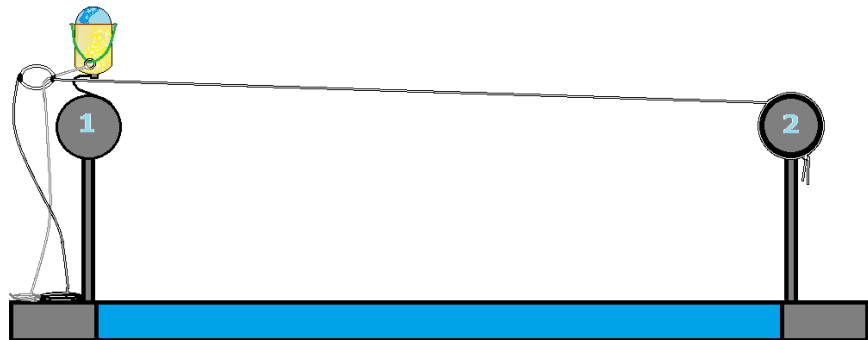

Use blind plugs to both camera and cable connections when these are no longer connected. Take good care of all loose blind plugs

- 5 Execute necessary service on the camera

- 6 When service is done, remove blind plugs and connect camera to cable. Make sure that the vertical rope goes through the nylon ring before attaching the camera to this rope



Make sure to thread the rope through the nylon ring before attaching it to the camera's fastening ring

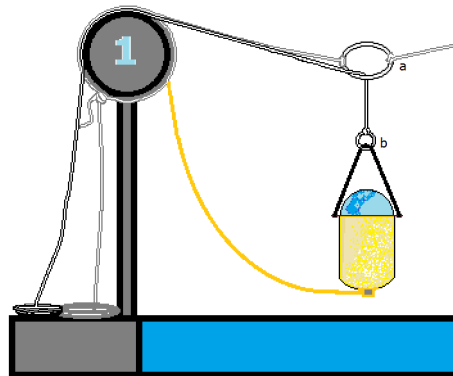

- 7 Loosen the horizontal rope in pt. 1 and release enough rope to pull the nylon ring and camera back into position
- 8 When the camera is in correct, horizontal position, lower it to desired depth using the vertical rope. Make sure to fasten all rope ends properly to the cage edge after the camera is properly placed inside the cage.

5 Camera suspension with winch: Installing winch



Safety garments and antiskid foot wear is mandatory when working on or by the cage edge



During installation, make sure that ropes from the winch parts are not hanging down to ensure that noone steps on them, risking both dropping the winch in the water as well as personnel injuries



Both methods for installing Winch C5 on operating CAP and CAP connection box require two people working on the same installation



Be careful not to drop any parts in the sea water during the installation process

The various winches require various suspensions, so make sure to follow the correct instructions. Each instruction page is marked with belonging winch to ensure correct installations and suspensions. Illustrations marking which winch the instructions are ment for:



Winch V5 is controlled by AKVAconnect 2.11. See separate manual for how to connect winch to system after installation.

Most AKVA user manuals, including AKVAconnect manuals, are found in www.akvagroup.com/products/user-manuals, and may be read and downloaded from here.



5.1 Winch V5 installation



Installation of Winch V5 requires two people because of its weight. Two people are required both for installation on already used CAP and for installation in CAP box

The new Winch V5 is installed on a CAP connection box or in an operating Digital CAP. Connection box installation:



The yellow winch cable must point in towards the connection box to prevent it from conflicting with other ropes and suspensions inside the cage.

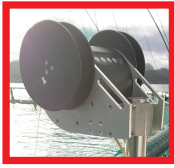

5.1.1 Preparing the CAP connection box

This CAP connection box preparation must be performed on land or indoors in the the barge

Two rails are attached to the back side of the CAP connection box. Before Winch V5 and CAP connection box are transported out to the cage, two unistrut nuts must be attached to each rail.

Procedure:

- 1 Read through this entire procedure before commencing the process
- 2 Make sure that both rails are attached to the back side of the connection box. If they are not, attach them
- 3 Tread a unistrut nut in to each side of each rail: press the spiral flat, and push the nut in to the rail

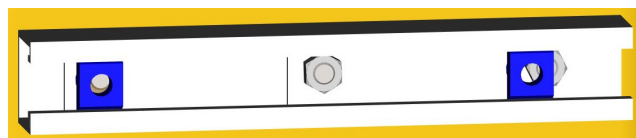

Two unistrut nuts (blue) are placed in each side of the rail

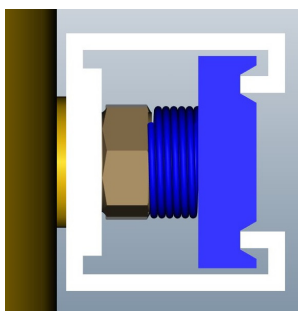

Unistrut nut placed correctly inside a rail, side view



Unistrut nut

- 4 Bring connection box and Winch V5 to the cage for installation. Make sure to install according to cage type!



5.1.2 Attaching CAP connection box to Polarcirkel and single steel poles

Necessary equipment:

- 1 x 18mm open end spanner (wrench)

Procedure:

- 1 Read through this entire procedure before commencing the process
- 2 Bring all parts and necessary equipment to the cage
- 3 Place the CAP connection box next to the cage

- 4 Place a clamp around the pole, adjust the unistrut nuts so that their holes are in center with the clamp holes

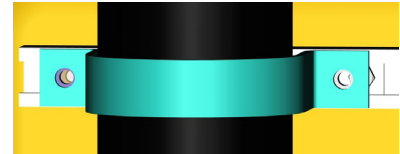

- 5 Attach the clamp to the rail via the unistrut nut with M12 bolts

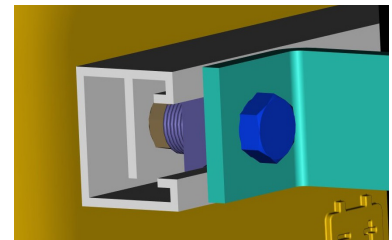

- 6 Tighten the bolts after all are attached and everything looks straight and ok. Tighten well, so that all stays in place during rough seas.



5.1.3 Attaching CAP connection box to double steel poles

Use this method for installing connection box and Winch V5 AKVA groups Wavemaster steel cages with double poles

Required tools:

- 2 pc. 10mm (= 7/16 inch) open end spanner/wrench

Procedure:

- 1 Read through this entire procedure before commencing this installation process
- 2 Release the left and the right bolt in the upper rail and tread the clamps in to the rail as illustrated below:

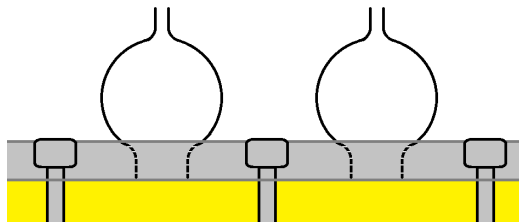

- 3 Re-attach the left and the right bolts
- 4 Repeat procedures 2 and 3 for the lower rail
- 5 Bring all belonging parts to the cage edge
- 6 Place the connection box next to the desired cage pole
- 7 Place all pipe clamps around the pole, and fasten them with the M6 bolts by using one wrench on the bolt and the other on the nut
- 8 Tighten bolts well to make sure that the connection box stays in place, even during and after larger cage movements.

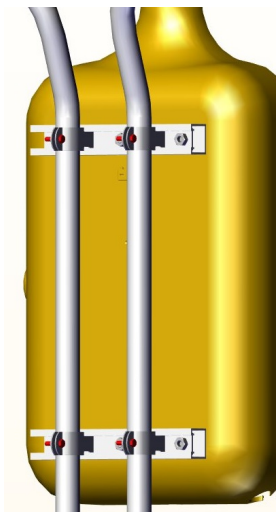



5.1.4 Attaching Winch V5 to the CAP connection box

Two methods:

- attach to a operating CAP (top is attached to the pole)
- attach to a CAP battery box



Installation of Winch V5 requires two people because of its weight



Both installation participants must read through the procedure they are using before commencing the installation process

Procedure for attaching Winch V5 to operating CAP with top:

- 1 Unscrew all 4 bolts from the winch bracket, make sure to keep them from falling into the sea!
- 2 Place the winch next to the CAP pole
- 3 Re-attach the bracket piece using all 4 bolts. Do not tighten the bolts before all are attached.

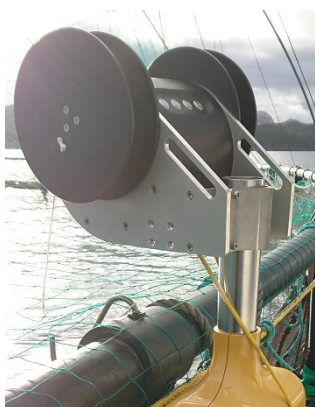

Procedure for attaching Winch V5 to connection box:

- 1 Loosen the bolts to increase the bracket opening, do not remove the bolts
- 2 Thread the bracket over the pole
- 3 Fasten the bracket by all 4 bolts. Do not tighten the bolts before all are attached.

5.2 Installing Smartwinch and Winch HT in steel cages



Read through the procedure they are using before commencing the installation process.

Procedure:

- 1 Fasten the bolts to the affix brackets before installation
- 2 Place the winch bracket and affix brackets (with bolts) on the front and back side of the cage pole in desired position. The winch should always be placed on the inner side of the pole
- 3 Fasten bolts to the bracket and tighten well, so that the winch does not move downwards along the pole. Avoid fastening the bolts too tight, this may cause the brackets to bend.



5.3 Installing Smartwinch and Winch HT in plastic cages

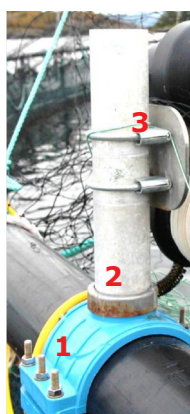

Procedure:

- 1 Install a winch tapping sleeve that fits the cage edge diameter in desired position. Tighten the six bolts, so the tapping sleeve stays in this position. Make sure to use a tapping sleeve that fits the cage edge diameter
- 2 Screw the pole to the winch tapping sleeve
- 3 Attach the U-clip to the winch bracket around the pole in desired vertical position. Fasten the four nuts inside the winch bracket and tighten properly (but not so tight that the bracket bends). Make sure that the bracket sits tightly, so that it does not move up or down the pole if the cage edge moves.

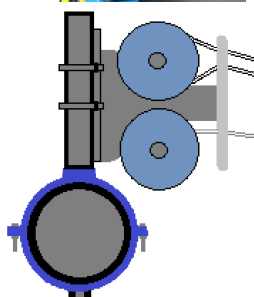

6 Camera suspension with winch



Safety garments and antiskid foot wear is mandatory when working on or by the cage edge



For manual camera depth control with, mark the cable with tape, waterproof pen or other waterproof markers for every or every other meter of cable. This may be useful for both cameras installed with and without winch.



Because of various movements in plastic cages, noone can guarantee that a certain type of suspension is the best for all cages in all locations. The next chapters show examples of suspensions for AKVA winches, and these methods will work for most locations and cage sizes.



Use recommended knots from chapter 1.4 for all rope attachments

The various winches require various suspensions, so make sure to follow the correct instructions. Each instruction page is marked with belonging winch to ensure correct installations and suspensions. Illustrations marking which winch the instructions are ment for:



6.1 Suspensions for Winch V5

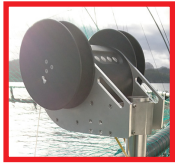

If the fastening holes in the camera bracket are too narrow, they can be drilled to 5mm so that the winch ropes may be tread through and attached



Read through the entire procedures before commencing the installation process



Make sure that the winch ropes are not in conflict with other equipment inside the cage during stand by nor during use. Run the camera in and out, up and down, and to its "home" position to discover potential conflict



Install the Winch V5 to the CAP/CAP battery box as described in chapter 5.

Rope lengths:

Winch V5 is delivered with 230' rope on the M1 drum and 460' rope on the M2 drum. These lengths are customized for large cages, from 525' and up. For smaller cages the rope must be shortened, and this is done by pulling out 100' from both drums, and cutting by the 100'-mark.

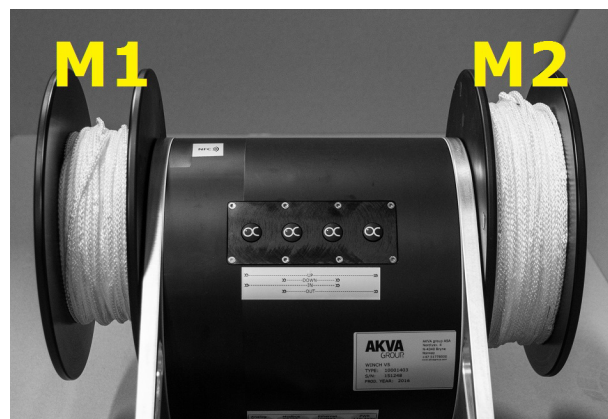

Cage size	M1 rope length	M2 rope length
Larger than 585'	230 feet	460 feet
585' or less	180 feet	360 feet



Install CAP or CAP battery box on the cage edge as explained in chapter 5, and adjust rope length as shown in chapter 6.1.1.

To avoid damages to the M2-rope, tread it through the hamster wheel (over the bottom ring and under the top ring). If the rope is placed under the hamster wheel, growth and sprout that may grow under the ring placed in the salt water may tear the rope.

Procedure:

- 1 Tread the end of the M2 rope through the snatch block
- 2 Attach the elastic band to the snatch block via the safety hook
- 3 Bring elastic band, snatch block and rope from M2 over to the other side of the cage. Tread it through the hamsterwheel, between the top and bottom rings, if hamsterwheel is installed in the cage
- 4 Attach one end of the elastic band to a cage pole as illustrated here:

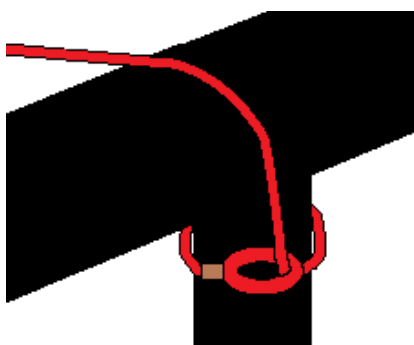

- 5 Bring the rope back to the winch and attach it to the camera bracket (this rope goes under the hamsterwheel bottom ring)
- 6 Attach the rope from M1 to the camera bracket and place the camera in the sea
- 7 Make sure that the camera and its ropes do not conflict with other equipment installed in the cage. Run the camera up, down, in and out to control. Adjust placement if necessary.



Principal for installation in cages with hamster wheel

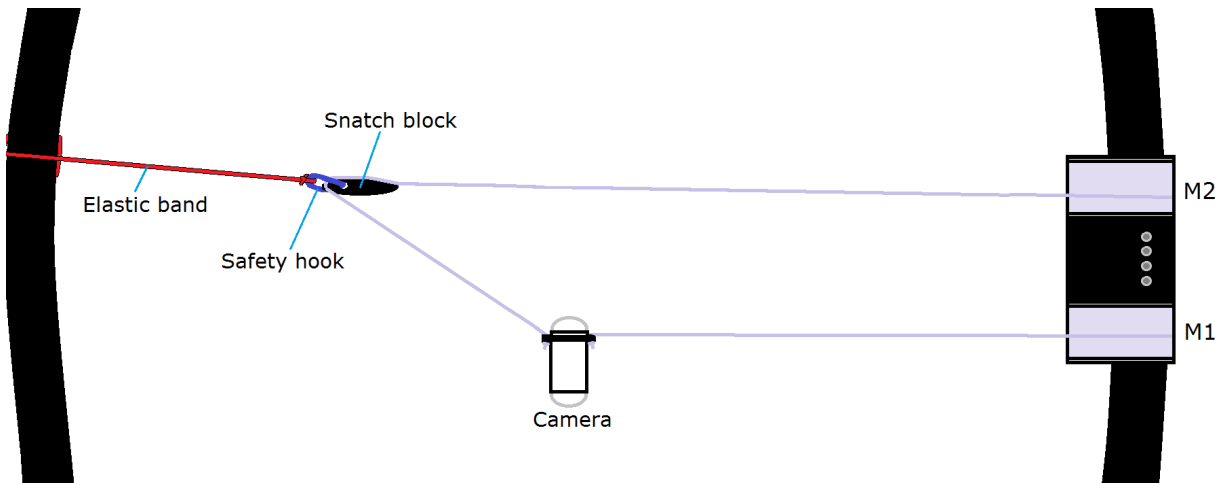

Principal for installation in cages with hamster wheel

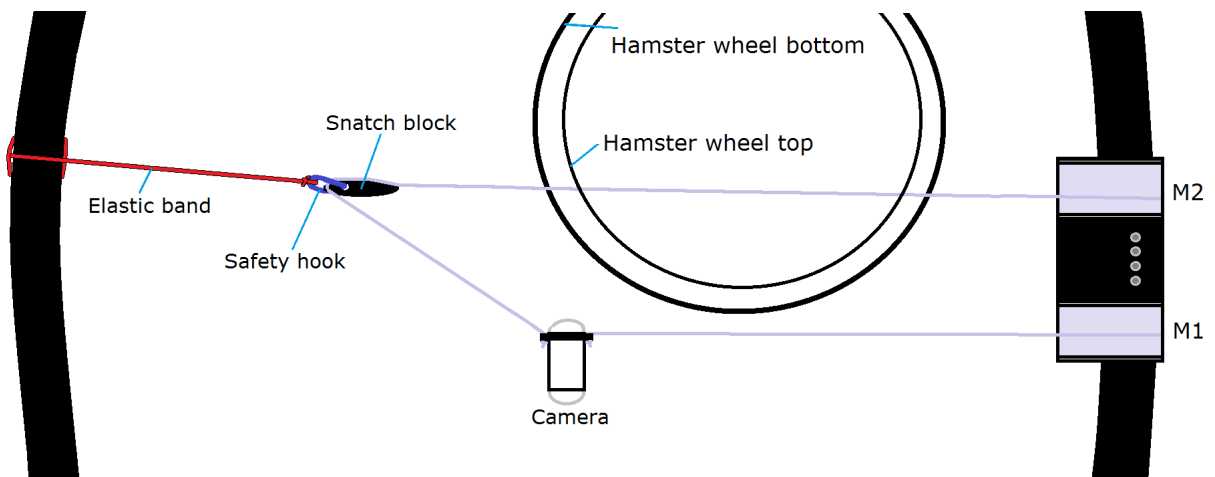

6.2 Suspension for Smartwinch HT



Safety garments and antiskid foot wear are mandatory when working on or by the cage edge



Because of the hamster wheel inside the plastic cages, conflict between sprout on the bottom of the hamster wheel and the rope may occur. To avoid this, we strongly recommend placing the top rope through the hamster wheel and let only the rope that the camera is attached to go underneath the hamster wheel to avoid gnaw on the top rope.



In steel cages, the suspension used for Smartwinch (old type, as described in chapter 6.2) may be used.

Necessary equipment:

- Two people
- Everything in the shipment (check the service note)

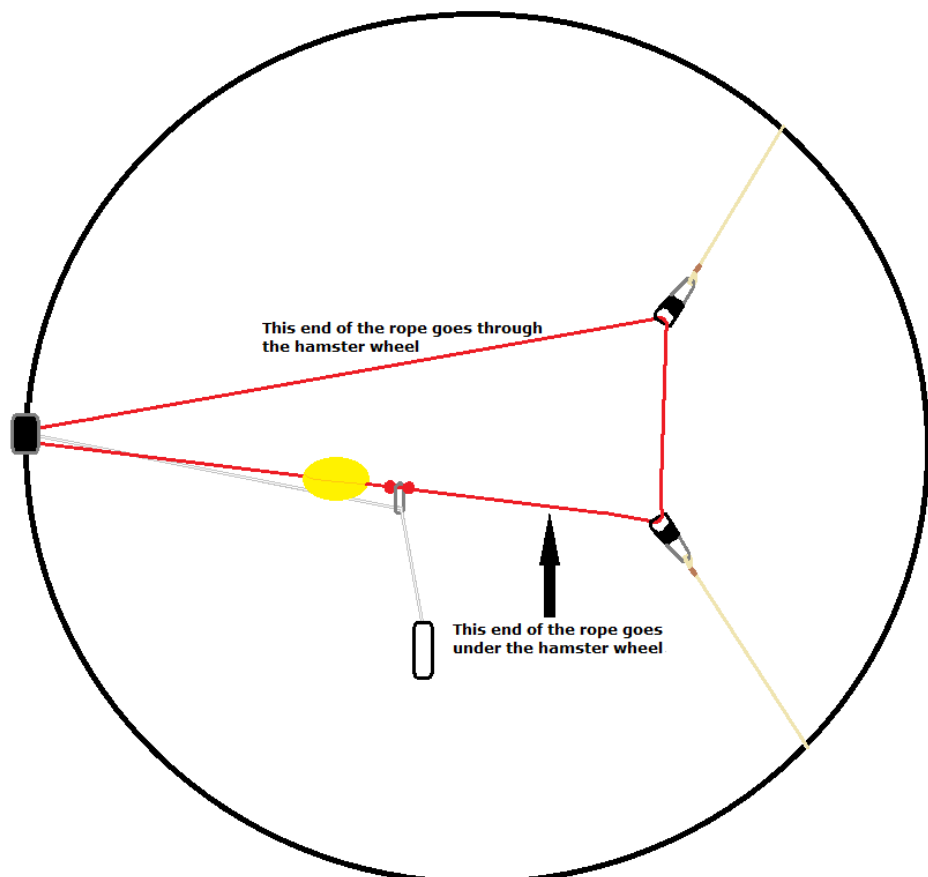



Full instructions for suspension with SmartWinch HT

- 1 Read through this entire procedure before commencing the installation process
- 2 Tie a knot 50 centimetres in on one of the ends of the red rope, thread a 50mm safety hook into the rope and tie another knot



Make sure that there is enough rope outside of the knots to tie both ends of the red rope together with bowline knots



The purpose of these knots is to stop the safety hook to slide across the rope. The white rope is attached to this safety hook before attaching the camera

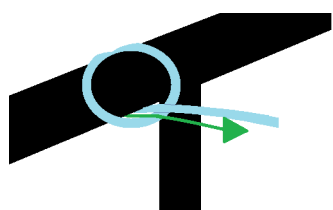

- 3 The elastic bands are fastened to the cage handrail by placing it around the edge, and treading the ends through the loops. Fasten the elastic bands with about 1/4 of the cage circumference distance between (this distance depends on the cage size)



- 4 Attach the ends of the white elastic bands to each safety hook and attach one safety hook to each pulleys

- 5 Fasten the red rope to the pulleys

- 6 Pull the red rope through the hamster wheel and through the brackets top right side



- 7 Whirl the rope four times around the upper winch and pull it out from the brackets left side



- 8 Attach the red rope ends to each other using bowline knots

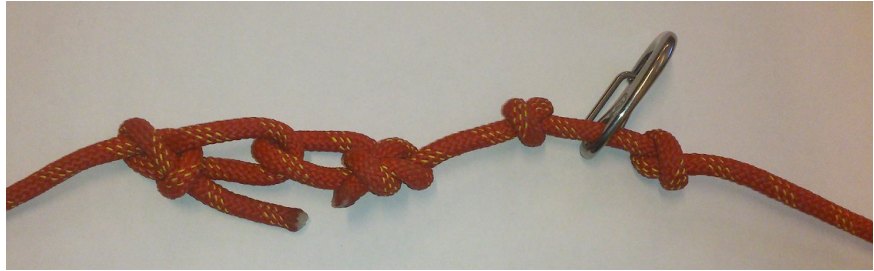

- 9 Pull the white rope from the lower winch through the lower bracket opening

- 10 Attach a pulley to the 50mm safety hook on the red rope (between the two knots from pt.1)

- 11 Thread the white rope through the pulley and attach it thoroughly to the camera.



If the knot attaching the camera to the white rope is not fastened properly, the knot might loosen and the camera may fall into the cage and in worst case do damages to the net

Hint!



A signal coloured buoy may be helpful to show the camera's position in the cage. This buoy is then thread on to the red rope before the ends are attached, and will stay in the water surface always indicating where the camera is positioned



Quick guide for suspension with SmartWinch HT

- a Tie a knot about 50 centimeters in to one end of the red rope
- b Slide a 50mm safety hook in to the rope and tie another knot
- c Fasten two elastic bands to the handrail, with about 1/4 of the cage circumference distance between
- d Fasten the elastic bands to one safety hook and one pulley each and pull the red rope through both pulleys
- e Thread the red rope through the hamster wheel
- f Thread the red rope through the winch bracket and whirl it four times around the winch
- g Fasten the red rope ends to each other using bowline knots
- h Thread the white rope from the lower winch through the lower part of the bracket
- i Fasten a pulley to the 50mm safety hook on the red rope and pull the white rope through the pulley
- j Fasten the camera properly to the white rope.

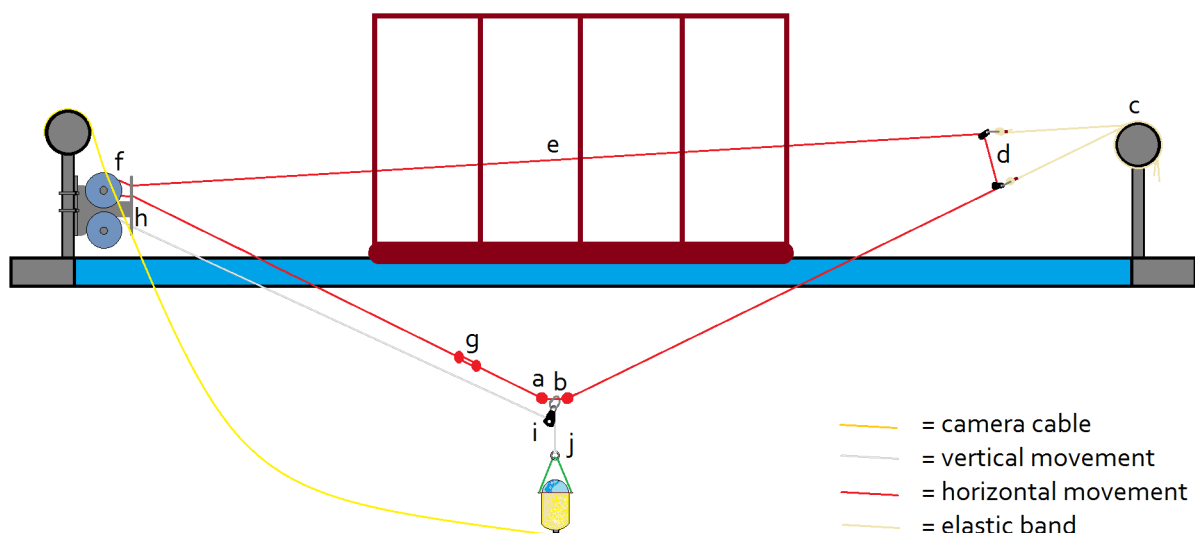

6.3 Suspension for Smartwinch



Safety garments and antiskid foot wear is mandatory when working on or by the cage edge

- 1 Read through this entire procedure before commencing the installation process
- 2 Attach two elastic bands to the cage handrail in the opposite side of the cage from the winch, by placing it around the edge, and tread the ends through the loops (see illustration below)



Tighten the elastic bands properly. Check and tighten them regularly and more often in stormy seasons

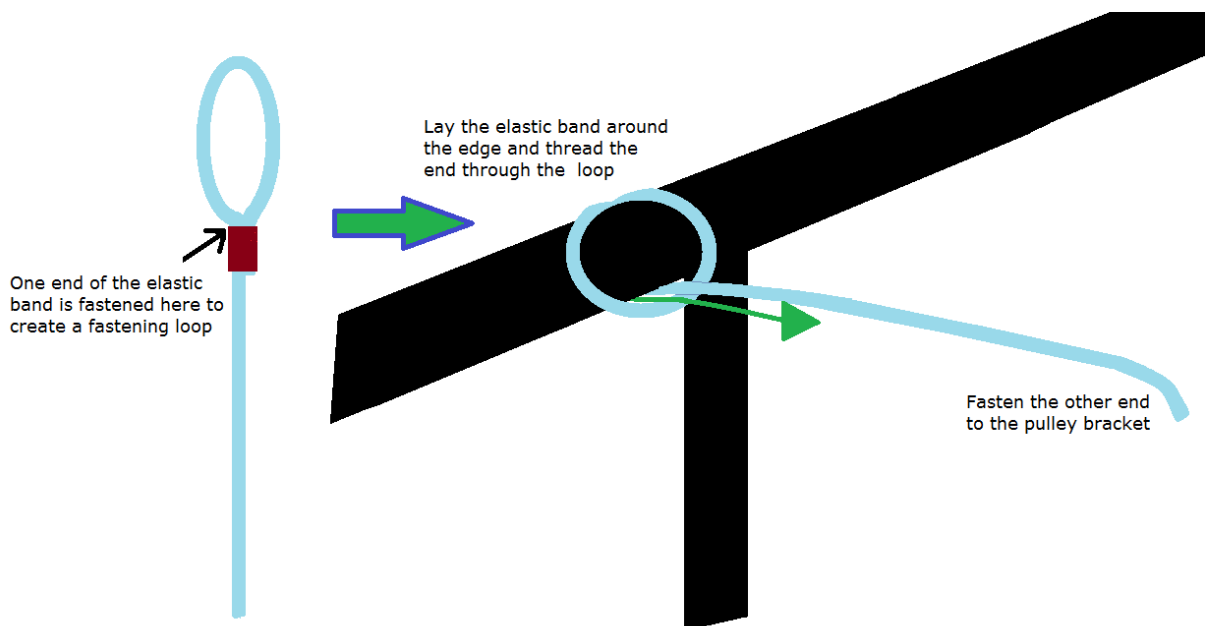

We recommend placing the elastic bands with 2-3 cage poles in between (depending on the cage size).



See illustration in the next page

- 3 Fasten the other ends of the elastic bands to the pulley bracket by tying them to safety hooks that are fastened to the pulley



Steel cage:

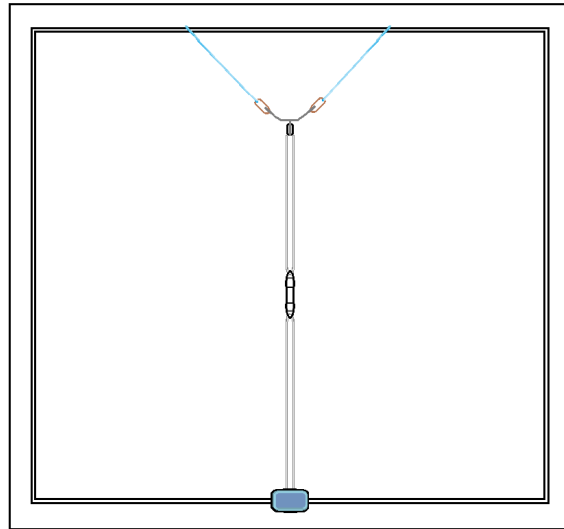

Plastic cage:

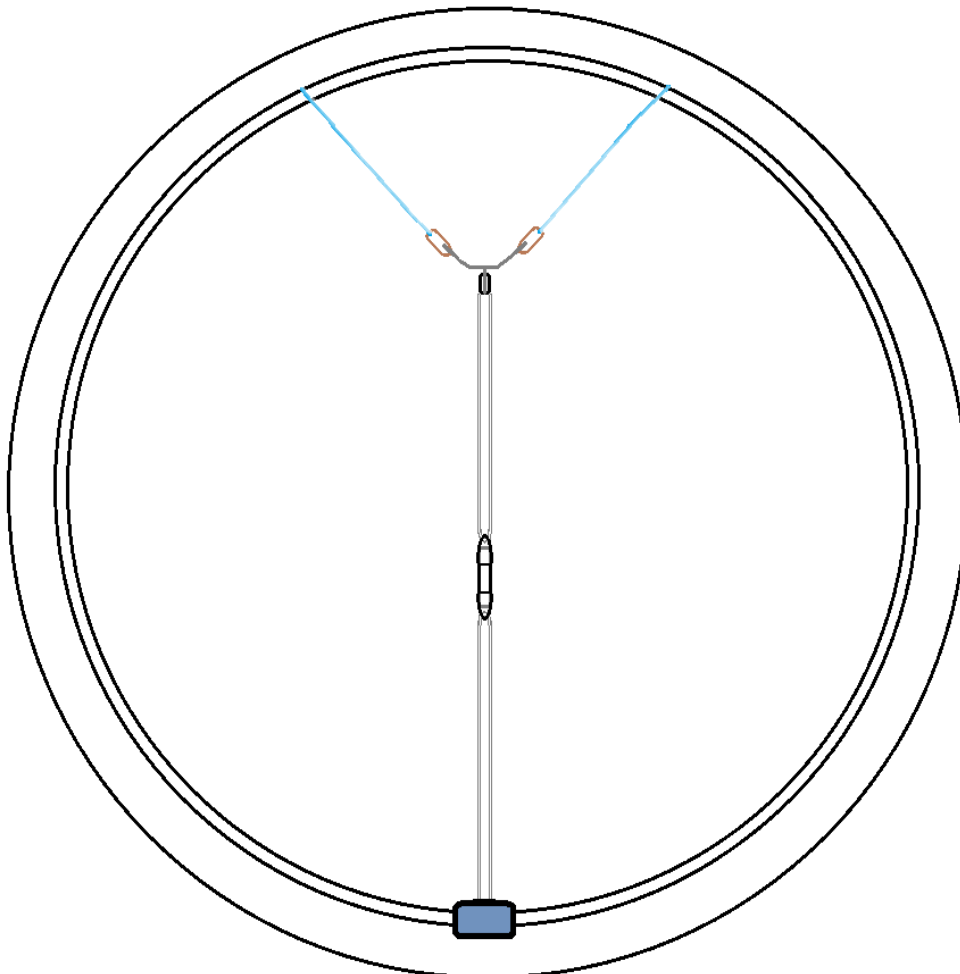



4 The rope in the upper winch controls the cameras horizontal position inside the cage. Fasten this rope to a double pulley in each end, tread it through the bracket top opening and turn it one time around the upper winch, and tread it back through the brackets top opening and then through the three pulley wheels. See "quick guide" installation instructions under the drawing

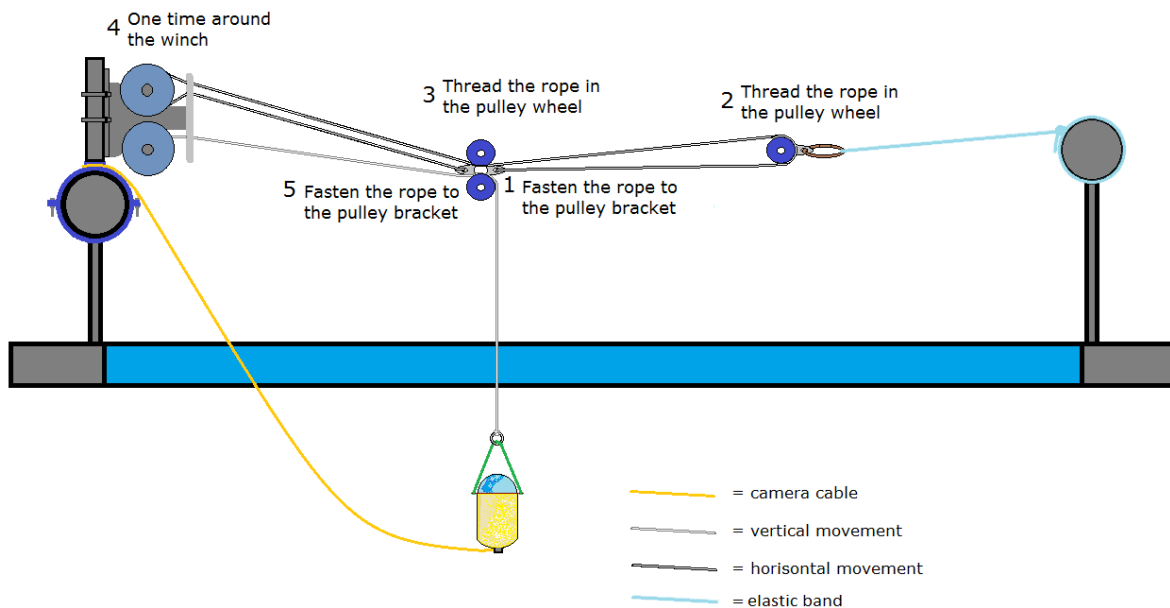

- a Bring ropes and the double pulley to the opposite side of the cage from the winch
- b Tie the rope to the pulley bracket (pt 1) with a bowline knot
- c Pull rope to pt 2 and tread it through the pulley wheel (pt 3)
- d Pull rope to pt 3 and tread it through the pulley wheel (pt 2)
- e Bring the rope to the winch and the double pulley to the winch
- f Tread the rope through the top opening in the winch bracket
- g Turn the rope one time around the top winch (pt 4)
- h Tread the rope through top opening in the winch bracket
- i Tie the rope to the pulley brackets second hole (pt 5), using a bowline knot.



- 5 The lower winch controls the camera's vertical position inside the cage. Pull the rope through the bracket (pt. 1) and through the lower pulley wheel (pt. 2), then attach the rope to the camera's nylon fastening ring (pt 3) with a bowline knot.

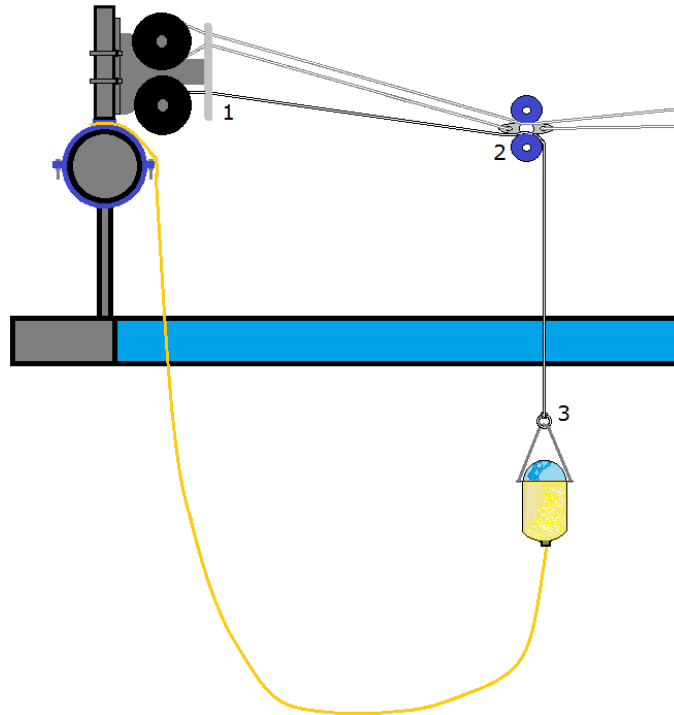

If the knots are not done well enough, the camera may loosen and cause damage to the net

7 Using Winch V5

7.1 Manual control

Winch V5 may be controlled both by using the buttons on the winch body:

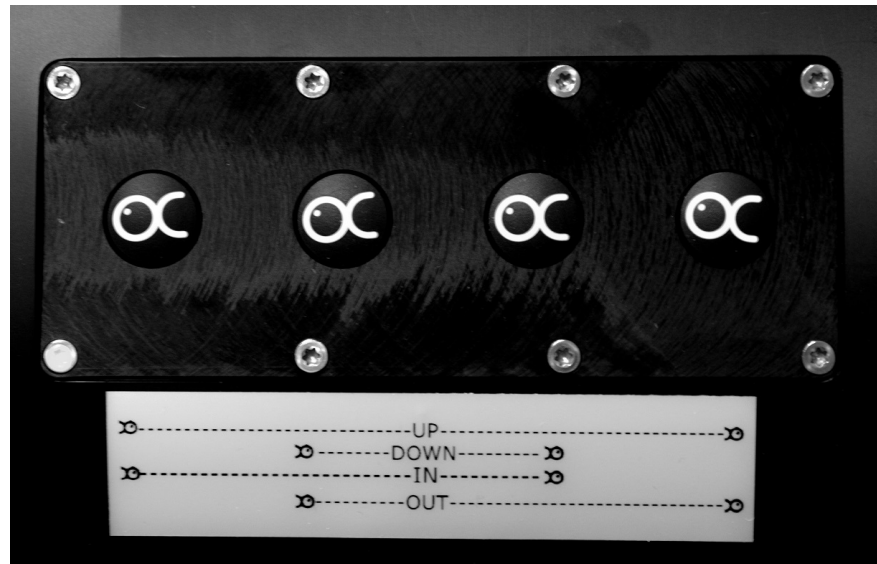

Press the following buttons at the same time to move the camera around inside the cage:

Button 1 + 4: UP

Button 2 + 3: DOWN

Button 2 + 4: OUT

Button 1 + 3: IN

7.2 Software control

Winch V5 may also be controlled by AKVAconnect 2.11, see separate user manual for how to connect winch to system after installation. Most AKVA user manuals, including AKVAconnect manuals: www.akvagroup.com/products/user-manuals, read and download from here when available.



8 Camera power supply and signal transmission

Power supply for cameras are given through AKVA SmartCAP, SmartBox or CSU. These devices transform voltage from the barge into 12V. If these devices are not used, a 12V battery will provide necessary power. SmartBox and CAP also receive signals from the cameras and send these wireless back to the barge.

8.1 Wireless transmission, signals to and from winch and camera

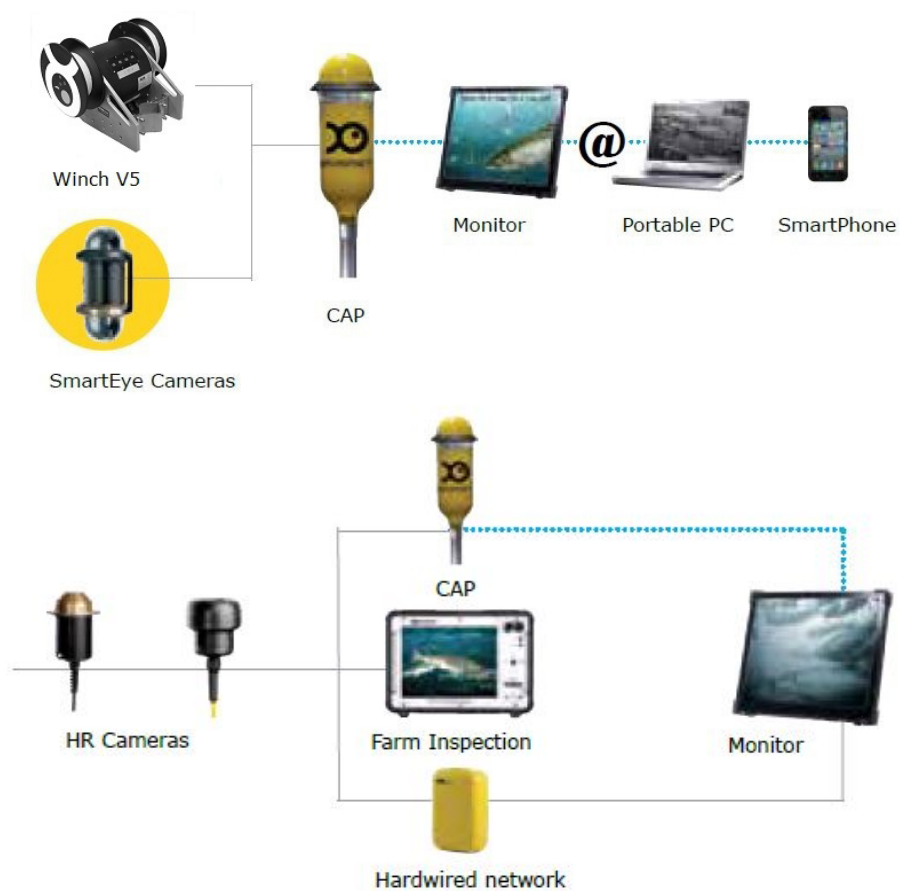

8.2 Hardwired transmission, signals from cameras



9 Maintenance



Safety garments and antiskid foot wear is mandatory when working on or by the cage edge

We recommend cleaning all cameras, winches and their belonging components once a month with fresh water and a mild washing up liquid, and more often in periods with a lot of bad weather. Rinse off all sprout and salt water particles.

We recommend that all components are maintained at the same time, to simplify the maintenance plan.

9.1 Winch

Clean the winch once a month. Use fresh water and a mild washing up liquid to rinse off salt water and salt water crystals, to avoid corrosion to the winch materials and damage to the ropes. During this cleaning process, also control the functions of the equipment. Contact AKVA group support if anything wrong is discovered, or if service or additional maintenance is necessary.

9.2 Ropes and elastic bands

Ropes and elastic bands in the winch and the camera suspensions should be checked for crossing and twirling at least once a week.

Elastic bands need to have their elastic capacity tested regularly. If the elasticity is too low, they need to be replaced. Clean off all sprout and salt water and salt crystals, and rinse with fresh water. Do this while maintaining the winch.

9.3 Pulleys

Control that all of the pulleys are intact, by rolling their wheels. They should roll freely, without any obstacles. Check these once a week, more often during bad weather.

9.4 Camera



Never use any kind of scrubbing products when cleaning cameras. The dome will become scratched and eventually non-transparent and useless.

Bring the camera over the cage edge and clean off sprout with fresh water and a mild washing up liquid. Use a soft cloth or brush to avoid scratching the camera glass dome.

Do this minimum twice a year, and if any sprout is visible in the transmitted video or images. Rinse all ropes with fresh water. Control the equipment and make sure that everything is as it should. Contact AKVA if anything wrong is discovered with the camera or the winch, or if service or additional maintenance is necessary. Contact information is found in the back of this manual.



Parameter	Weekly	Monthly	Comments
Clean everything with fresh water		X	Including cameras, ropes/suspensions, winch, pulleys and similar
Control all equipment functions		X	Including cameras, ropes/suspensions, winch, pulleys and similar
Check ropes/suspensions for thwarts	X		Untie/release if necessary
Tighten suspensions	X		Control tightness, tighten when needed
Check elastic band elastics	X		
Check pulley rolling capacity	X		Change if stuck

9.5 Maintenance plans

Fill in the week number in the daily maintenance forms and the name of the month in the weekly form. This is important in order to maintain regularly maintenance.

When each task is performed, sign with in the correct box.

Make copies of the next two pages and keep these copies in a maintenance binder.



It may be a good idea to mark the last copy with a note that says "This is the last copy, make more before using this" in order to always have access to at least one copy.

9.6 Weekly maintenance



*Make copies of this form before filling anything in
Fill inn correct months and weeks
Sign with your initials in the square after the task is done*

Month:	Week__	Week__	Week__	Week__
Check ropes /suspensions for thwarts				
Tighten suspensions				
Tighten all fastening bolts				
Check elastic band elastics				
Check pulley rolling capacity				

Month:	Week__	Week__	Week__	Week__
Check ropes /suspensions for thwarts				
Tighten suspensions				
Tighten all fastening bolts				
Check elastic band elastics				
Check pulley rolling capacity				

Month:	Week__	Week__	Week__	Week__
Check ropes /suspensions for thwarts				
Tighten suspensions				
Tighten all fastening bolts				
Check elastic band elastics				
Check pulley rolling capacity				

Month:	Week__	Week__	Week__	Week__
Check ropes /suspensions for thwarts				
Tighten suspensions				
Tighten all fastening bolts				
Check elastic band elastics				
Check pulley rolling capacity				

9.7 Monthly maintenance



*Make copies of this form before filling anything in
 Fill in correct year and start registering in correct month
 Sign with your initials in the square after the task is done*

Year:	Jan	Feb	Mar	Apr	May	Jun
Clean everything with fresh water						
Control all equipment functions						

Year:	Jul	Aug	Sep	Oct	Nov	Dec
Clean everything with fresh water						
Control all equipment functions						

Year:	Jan	Feb	Mar	May	Jun	Jul
Clean everything with fresh water						
Control all equipment functions						

Year:	Jul	Aug	Sep	Oct	Nov	Dec
Clean everything with fresh water						
Control all equipment functions						

Year:	Jan	Feb	Mar	May	Jun	Jul
Clean everything with fresh water						
Control all equipment functions						

Year:	Jul	Aug	Sep	Oct	Nov	Dec
Clean everything with fresh water						
Control all equipment functions						

Appendix A - Index

B

blind plugs 9, 24, 25

C

CAP 16, 26-31, 34, 35, 46, 50

CSU 9, 46

D

depth 16, 20, 22, 25, 33

F

fresh water 7, 10, 47, 48, 51

H

handrail 20, 38, 40, 41

N

nylon ring 8, 20, 21, 23-25, 44

P

position 20-23, 25, 32, 34, 39, 43, 44

power 7, 9, 12, 46

pulley 10, 20, 38-41, 43, 44, 47, 48, 50

R

repair 5, 9, 23

S

safety hook 35, 38-41

SmartBox 46

sprout 10, 35, 37, 47, 48

T

tearing 9, 35

W

wireless 15, 16, 46

Appendix B - Deviation form



Make copies of this form before filling anything in

Deviation control nr.:	
-------------------------------	--

Unit:	Producer:	Prod.no.:	Purchase year:

Deviation description:

Follow up proposition:

Date and signature, declarer:

Follow up directed:

Status:

New action for deviation no.:

Date and signature, follow up:

Appendix D - Contact information

NORWAY - AKVA group ASA

Head Office

Nordlysveien 4

PO. Box 271

N-4340 Bryne

Norway

tel. +47 - 51 77 85 00

fax. +47 - 51 77 85 01

Support Hardware and AKVAconnect

tel. + 47 - 51 77 85 03

supportakvasmart@akvagroup.com

Support Fishtalk

tel. +47 - 73 84 28 20

supportfishtalk@akvagroup.com

DENMARK

AKVA group Denmark AS (Land Based)

Bødkervej 7A, 1.

7000 Fredericia, Denmark

t. +45 7551 3211

f. +45 7551 4211

AKVA group Denmark AS (Land based)

Roskildevej 342, Building 2

2630 Taastrup, Denmark

t. +47 7551 3211

SWEEDEN

AKVA group - Agent: Modus Trading AB

Färjegårdarne 7

78461 Borlänge, Sweden

t. +46 - (0)243 883 22

f. +46 - (0)243 21 17 78

modus@dalnet.se

FINLAND

AKVA group - Agent: OY MG Trading AB

Ivisnäsplanen 2E

SF-02260 Esbo, Finland

t. +358 - 9867 68422

f. +358 - 9867 68420

ICELAND

AKVA group - Agent

Wise lausnir ehf

Borgartun 26, 105 Reykjavik, Iceland

t. + 354 545 3200

f. +354 545 3232

UK (SCOTLAND)

AKVA group Scotland Ltd.

36F Shore Street

Inverness, Scotland, UK

IV1 1NF

t. +44 (0)1463 221 444

f. +44 (0)1463 223 535

GREECE

Akvasmart/Fishtalk - Agent:
Zellas Trading Company
Dodekanisou Str., GR-174 56
Alimos, Athens, GREECE
t. +30 - 210 7014881
f. +30 - 210 7012666
zellastrading@ath.forthnet.gr

TURKEY

AKVA group Kültür
Balıkçılığı Ekipmanları Ltd. Şti.
Yeni Küçük Sanayi Sitesi No:1-C19 Baharlı Köyü
48200 Milas, Muğla, TURKEY
t. +90 - 252 - 374 - 6434
f. +90 - 252 - 374 - 6432

TUNISIE

AKVA group - Agent: Société Méditerranéenne
d` Etudes et Conseils
72, Avenue Habib Bourguiba
2080 Ariana, Tunisie
t. +216 71 700 453
f. +216 71 700 297
smechg@gnet.tn

CANADA

AKVA group North America Inc.
1495 Baikie Road, Campbell River
BC, V9W 1R9 Canada
t. +1 - 250-286-8802
f. +1 - 250-286-8805

AKVA group North America Inc.
5251 Duke Street, Suite 606, Duke Tower,
Scotia Square
Halifax, NS, B3J 1P3 Canada
t. +1-902-482-2663
f. +1 - 902-405-3373

CHILE

AKVA group Chile
Ruta 5 Sur Km.
1030, Puerto Montt, Chile
t. +56 - 65 250250
f. +56 - 65 257119

AUSTRALIA

AKVA group Australasia
t. +61 400 167 188
cschafer@akvagroup.com